

OUTDOOR BOTTLE FILLER ANCHOR ASSEMBLY

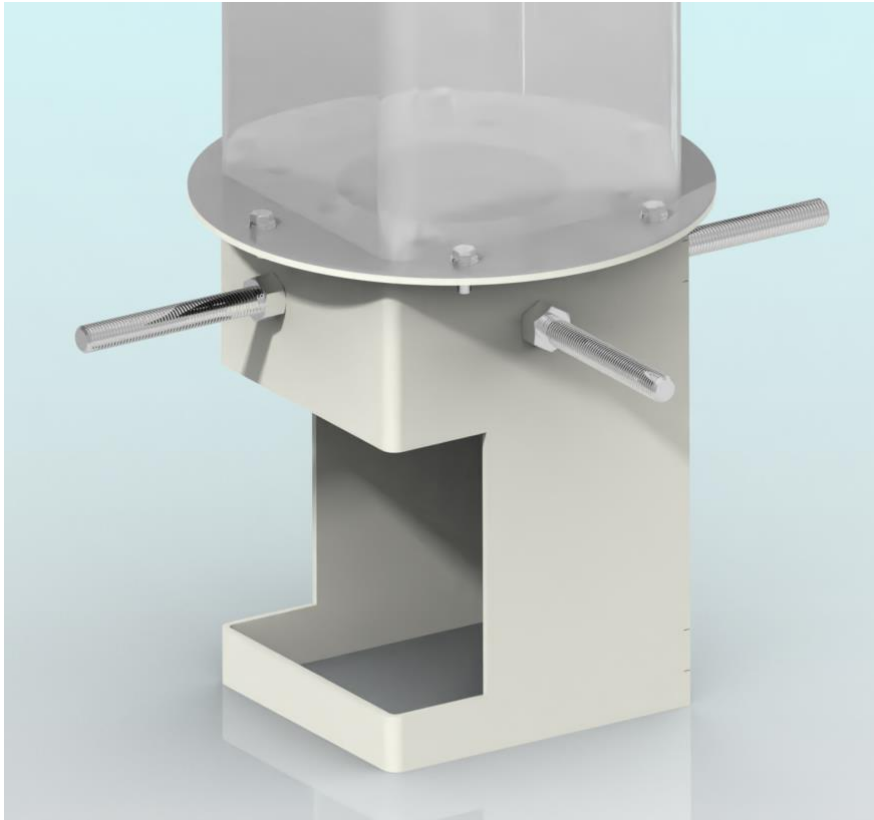

SECTION 1 – OVERALL DIMENSIONS

Dimension in brackets [] are in millimeters. Assembly weight is 15,4 kg [33,9 lb]

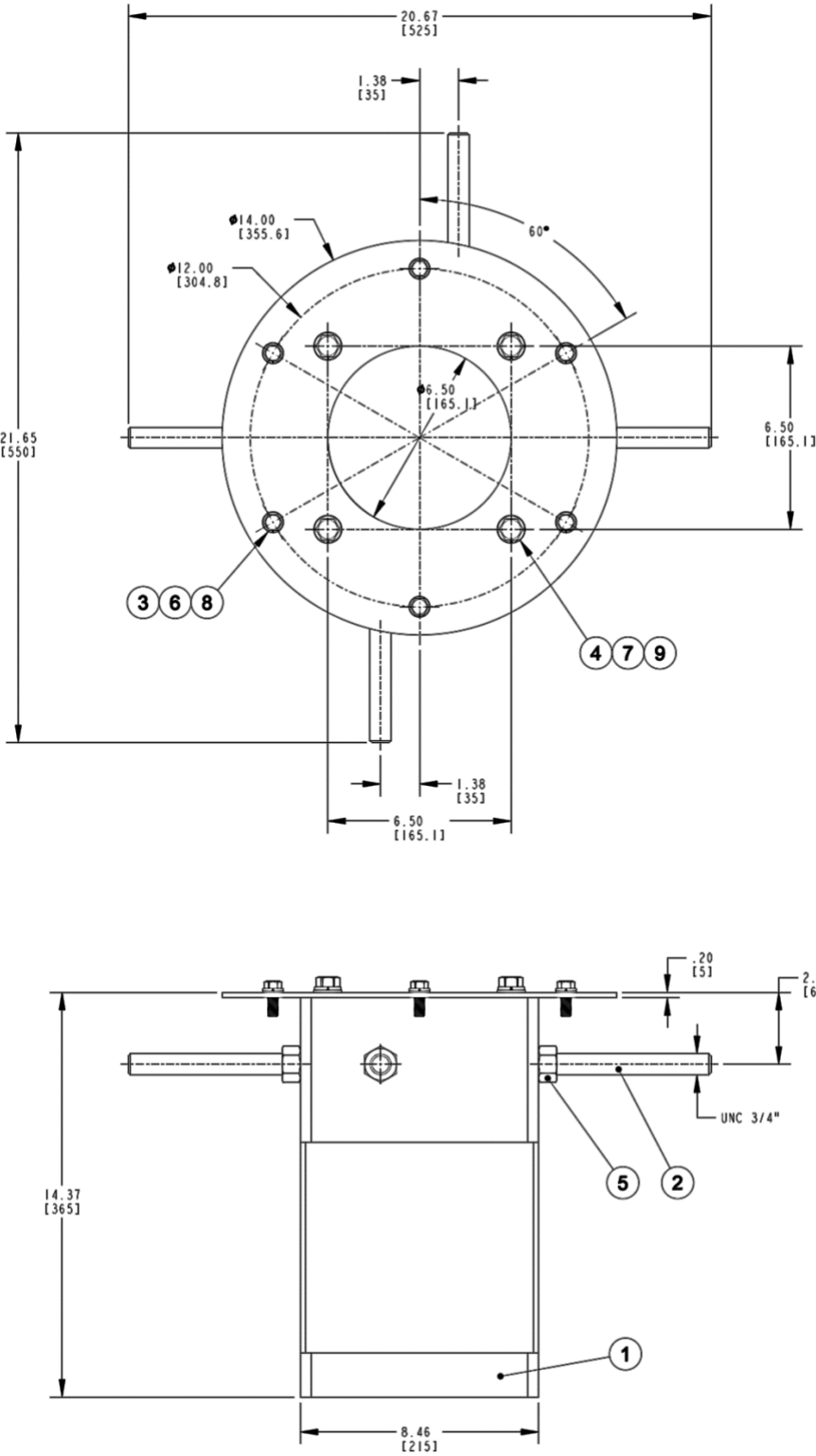

Fig.1 – Top & front view

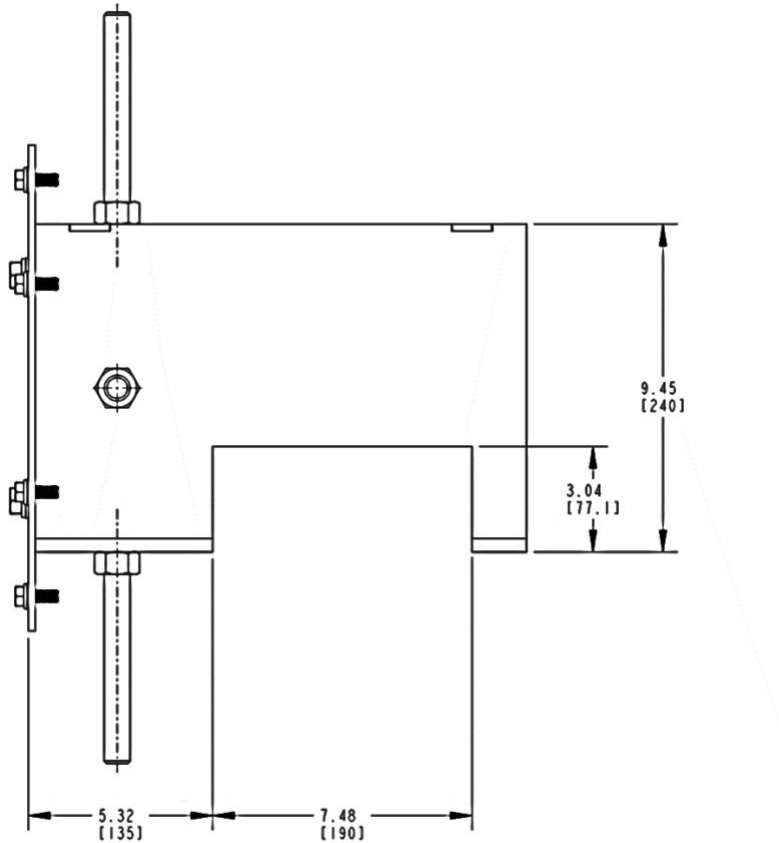

Fig.2 – Side view

SECTION 2 – INSTALLATION



WARNING: ALL SERVICE TO BE PERFORMED BY AN AUTHORIZED SERVICE PERSON

1. Inspect the carton and bottle filler for evidence of rough handling and concealed damage. Damage claims should be filed with the carrier.

NOTE: If anchor assembly is delivered together with free standing unit it can be found within it's packaging.

2. Packaging should include following elements (see section 1 for reference):

POS:	DESCRIPTION:	TOOL SIZE:	QTY:
1	ANCHOR ADAPTER	-	1
2	ROD	-	4
3	SCREW, HEX HEAD 3/8"x1,0	○ 9/16"	6
4	SCREW, HEX HEAD 1/2"x1,0	○ 3/4"	4
5	HEXAGONAL NUT 3/4"	○ 1-1/8"	4
6	PLAIN WASHER 3/8"	-	6
7	PLAIN WASHER 1/2"	-	4
8	SPRING WASHER 3/8"	-	6
9	SPRING WASHER 1/2"	-	4
10	INSTALLATION GUIDE	-	1

3. Install threaded rods [2] into anchor adapter [1]. Secure into position with hexagonal nuts [5]
4. Install fasteners into anchor adapter top flange.
Select one of two sets of fasteners:
 - 6 x 3/8" [3,6,8]
 - 4 x 1/2" [4,7,9]
5. Secure anchor assembly into concrete form as per standard practice.
6. After sufficient cure of concrete, remove fasteners from the top flange.
7. Place outdoor fountain on the anchor assembly and use fasteners again to secure it in place.

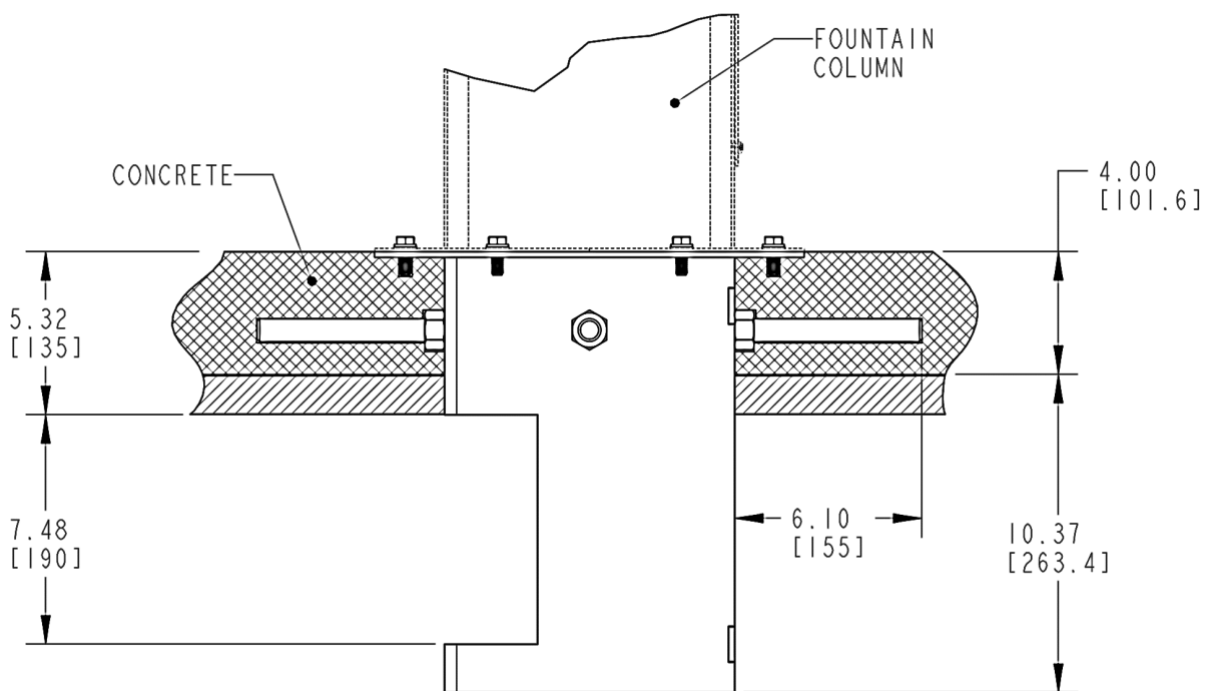

Fig.3 – Anchor installation

OASIS IRELAND
 Bunree Industrial Est., Ballina,
 Co. Mayo, Ireland F26 D5R3
 + 353 96 71222
 www.oasiscoolers.eu | info@oasis.ie

OASIS POLAND
 ul.Gutenberga 20,
 44-164, Gliwice Poland
 + 48 32 332 65 01