



VERSAFILLER PVSBF ■
 Manual, Non-Refrigerated, Vandal-Resistant
VERSAFILLER PV8SBFY ■
 Manual, Refrigerated, Vandal-Resistant
 Hydration Station Combo

This surface mount hydration station combo is manually activated. The bottle filler requires a push of the touch-button, while the drinking fountain is activated via the vandal-resistant touch-button

Key Versafiller moulded components shall contain Freshield, which utilises a silver-based antimicrobial compound that reduces the growth of micro-organisms and mildew to protect the surfaces from discolouration, odours and degradation.

Suitable for public building, gymnasiums, sports complexes, hospitals, schools, and offices.



MODEL CODE	PV8SBFY	PVSBF 507314
ACTIVATION	Bottle Filler: Manual (Touch-button) Drinking Fountain: Manual (Vandal-Resistant Touch-button)	
FILTRATION	Green Filter (optional), Built-in 100 micron strainer	
AUTO-OFF WATER FLOW	No	
DRAINAGE TYPE	Built in drain, Removable drip tray	
EXTERIOR CHASSIS DIMENSIONS	Antimicrobial ABS Plastic, Brushed Stainless Steel Heavy Duty Galvanised Steel 960(H) x 413(W) x 473(D)	
ALCOVE HEIGHT	330 mm	
NET WEIGHT	31 kg	16 kg
POWER SUPPLY	220-240V, 50/60 Hz	-
COOLING PERFORMANCE	60 LPH Rated Capacity & Base Rate (10°C in 21°C amb. temp.)	Non-Refrigerated
FULL LOAD AMPS	2.2A	-
RATED WATTS	450 W	-
ENERGY SYSTEM	Refrigeration is on only when in use or if water temp increases during long period of standby.	-
COUNTRY OF ORIGIN	Mexico	
CERTIFICATIONS	ANSI/NSF 61, CABO/ANSI A117.1, ADA, CE (LVD, EMC, RoHS), WRAS	
WARRANTY	1 Year	

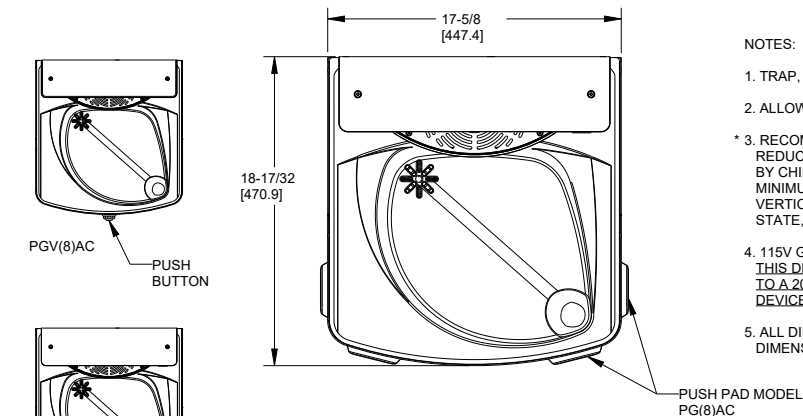

NOTES:

1. TRAP, STOP VALVE AND ELECTRICAL OUTLET NOT FURNISHED.
2. ALLOW 4 INCHES [102MM] MIN. PER SIDE FOR VENTILATION.
- * 3. RECOMMENDED ADULT BARRIER FREE HEIGHT UNINSTALLATION SHOWN. REDUCE HEIGHT BY 3 INCHES FOR INSTALLATIONS USED PRIMARILY BY CHILDREN AGES 12 AND YOUNGER. UNIT SHALL ALSO HAVE A MINIMUM CLEAR FLOOR SPACE 20[760] BY 48[1220]. ADJUST VERTICAL DIMENSIONS AS REQUIRED TO COMPLY WITH FEDERAL, STATE, AND LOCAL CODES.
4. 115V GROUNDED NORTH AMERICAN DUPLEX RECEPTACLE REQUIRED. THIS DRINKING WATER COOLER IS INTENDED TO BE CONNECTED TO A 20A MINIMUM GROUND FAULT CIRCUIT INTERRUPTING (GFCI) DEVICE TO MEET UL REQUIREMENTS.
5. ALL DIMENSIONS ARE IN INCHES. DIMENSIONS IN BRACKETS [] ARE IN MILLIMETERS.

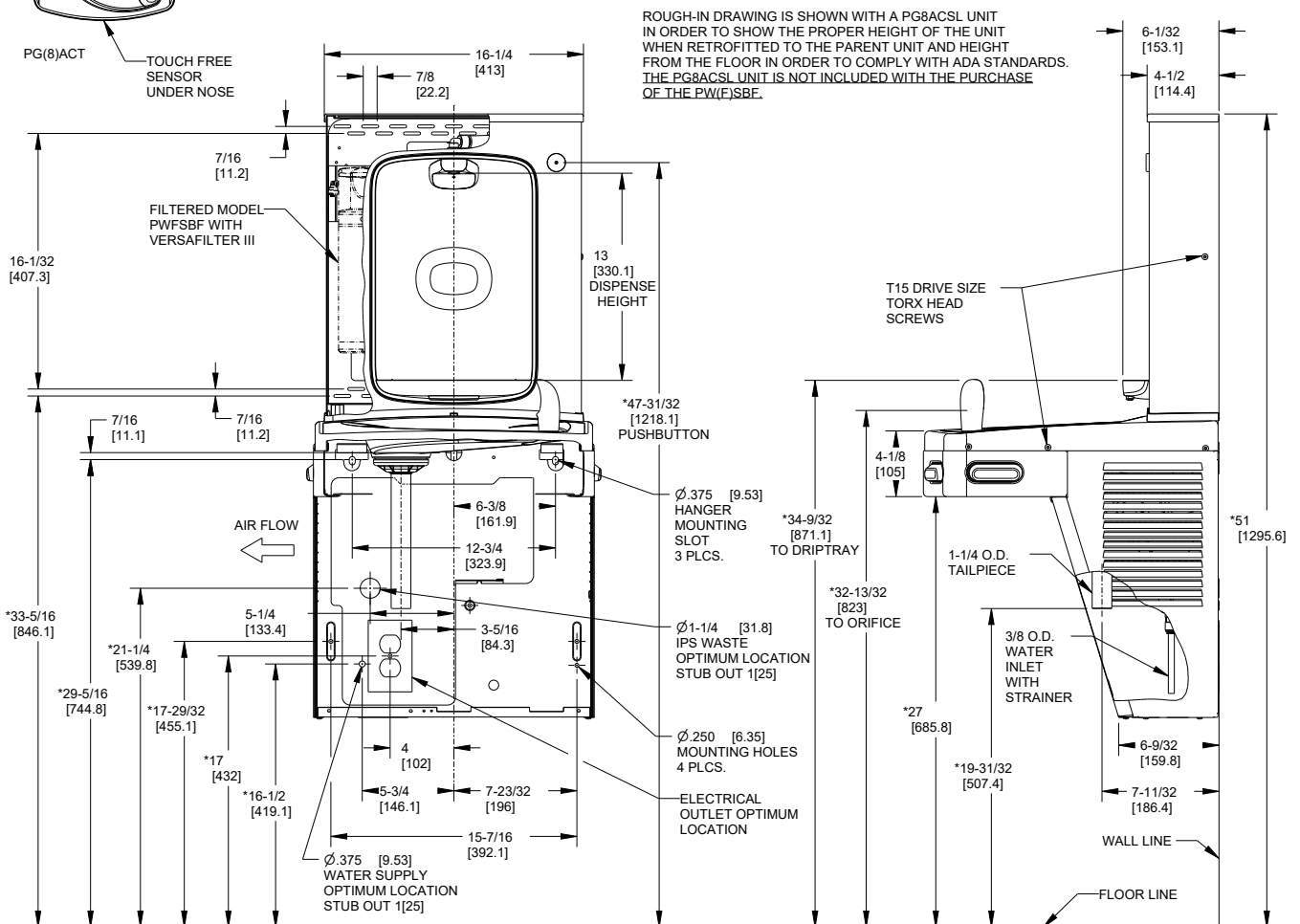

www.oasiscoolers.eu
info@oasis.ie

OASIS IRELAND
Bunree Industrial Estate, Ballina,
Co. Mayo, F26 D5R3, Ireland.
+353 96 71222

OASIS POLAND
ul. Gutenberga 20,
44-164, Gliwice, Poland
+48 32 332 65 01