



**VERSAFILLER PEBFTY** ■ Contactless, Non-Refrigerated  
**VERSAFILLER P8EBFTY 504959+507023** ■ Contactless, Non-Refrigerated  
 Hydration Station Combo

This surface mount hydration station combo features a completely contactless activation method. The bottle filler includes an electronic sensor for a contactless (touch free) activation and a 30 second shut off timer. The drinking fountain is activated via infrared sensor below the nose.

The Bottle Counter conveniently displays the number of times the unit has been used, encouraging the refill of sports bottles.

Key Versafiller moulded components shall contain Freshield, which utilises a silver-based antimicrobial compound that reduces the growth of micro-organisms and mildew to protect the surfaces from discolouration, odours and degradation.

Suitable for public building, gymnasiums, sports complexes, hospitals, schools, and offices.



MODEL CODE	P8EBFTY 504959E + 507000	PEBFTY 507076
ACTIVATION	Bottle Filler: Contactless (Infrared sensor) Drinking Fountain: Contactless (Infrared sensor)	
SENSOR COVERAGE	Up to 5cm (approx.)	
FILTRATION	Green Filter (optional), Built-in 100 micron strainer	
DISINFECTION	Quasar UVC-LED (optional)	
AUTO-OFF WATER FLOW	Bottle Filler: Yes ; Drinking Fountain: No	
DRAINAGE TYPE	Built in drain, Removable drip tray	
EXTERIOR CHASSIS	Antimicrobial ABS Plastic, Brushed Stainless Steel	
DIMENSIONS	Heavy Duty Galvanised Steel	
ALCOVE HEIGHT	960(H) x 413(W) x 473(D)	
NET WEIGHT	16 kg	16 kg
POWER SUPPLY	220-240V, 50/60 Hz	
COOLING PERFORMANCE	60 LPH Rated Capacity & Base Rate (10°C in 21°C amb. temp.)	-
FULL LOAD AMPS	2.2A	0.1A
RATED WATTS	450 W	7 W
ENERGY SYSTEM	Refrigeration is on only when in use or if water temp increases during long period of standby.	-
COUNTRY OF ORIGIN	Mexico	
CERTIFICATIONS	ANSI/NSF 61, CABO/ANSI A117.1, ADA, CE (LVD, EMC, RoHS), WRAS	
WARRANTY	1 Year	

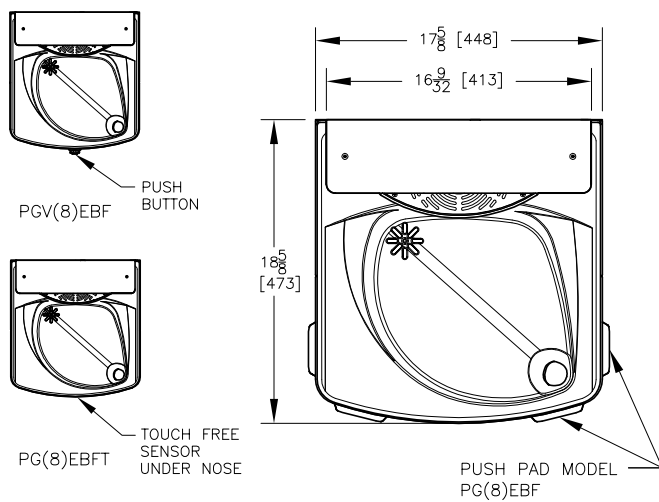

NOTES:

1. TRAP, STOP VALVE AND ELECTRICAL OUTLET NOT FURNISHED.
2. ALLOW 4 INCHES [102 MM] MIN. PER SIDE FOR VENTILATION.
- \*3. RECOMMENDED ADULT BARRIER FREE HEIGHT INSTALLATION SHOWN. REDUCE HEIGHT BY 3 INCHES FOR INSTALLATIONS USED PRIMARILY BY CHILDREN AGES 12 AND YOUNGER. UNIT SHALL ALSO HAVE A MINIMUM CLEAR FLOOR SPACE 30[760] BY 48[1220]. ADJUST VERTICAL DIMENSIONS AS REQ'D TO COMPLY WITH FEDERAL, STATE, AND LOCAL CODES.
4. 115v GROUNDING NORTH AMERICAN DUPLEX RECEPTACLE REQUIRED. THIS DRINKING WATER COOLER IS INTENDED TO BE CONNECTED TO A 20A MINIMUM GROUND FAULT CIRCUIT INTERRUPTING (GFCI) DEVICE TO MEET UL REQUIREMENTS.
5. ALL DIMENSIONS ARE IN INCHES. DIMENSIONS IN BRACKETS [ ] ARE IN MILLIMETERS.

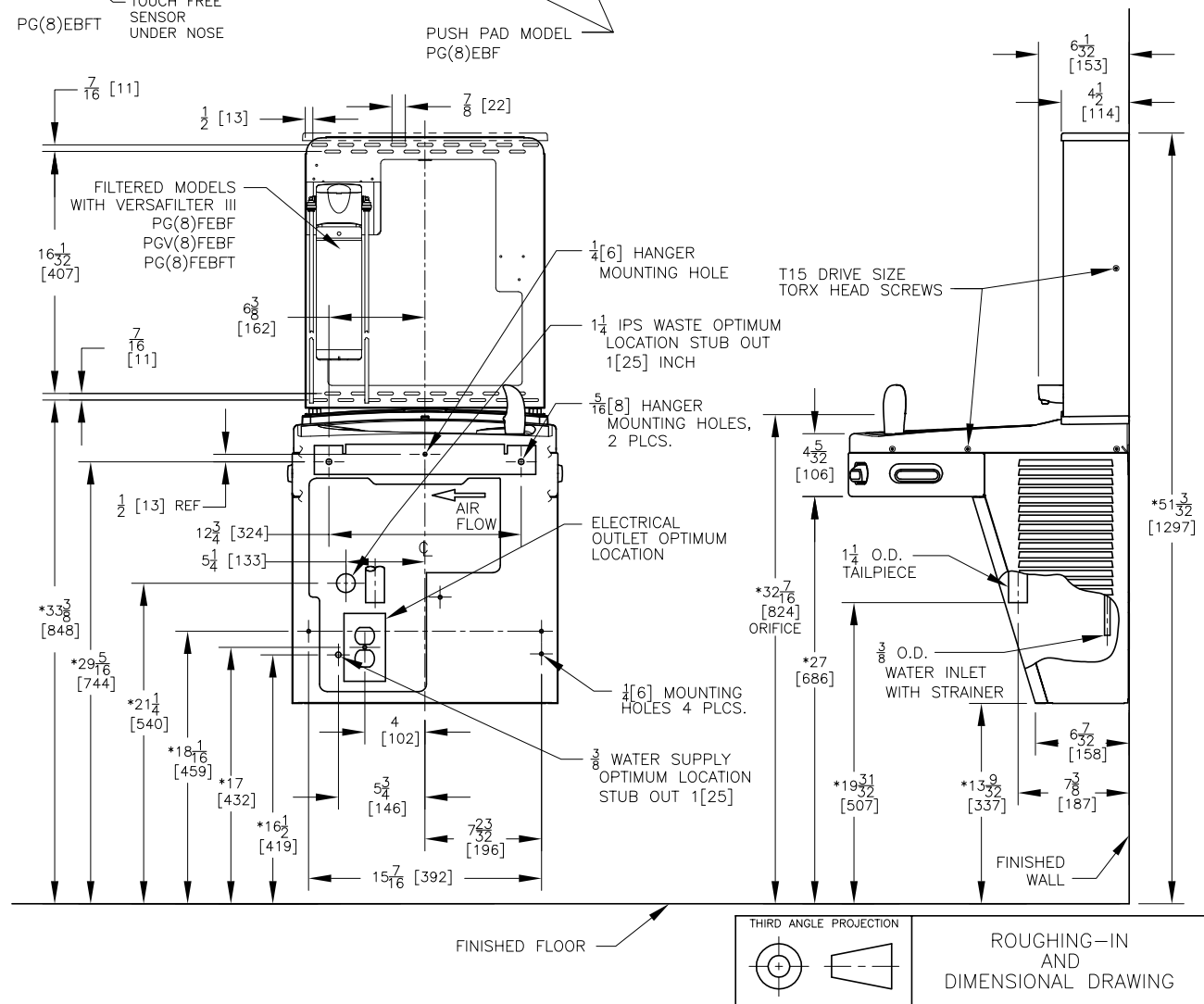

www.oasiscoolers.eu  
info@oasis.ie

**OASIS IRELAND**  
Bunree Industrial Estate, Ballina,  
Co. Mayo, F26 D5R3, Ireland.  
+353 96 71222

**OASIS POLAND**  
ul. Gutenberga 20,  
44-164, Gliwice, Poland  
+48 32 332 65 01

