



**M8WRSBFY** ■ Manual, Refrigerated  
**MWRSBF** ■ Manual, Non-Refrigerated  
 Hydration Station Combo

This surface mount hydration station combo is manually activated. The bottle filler requires a push of the touch-button, while the drinking fountains are activated via the push-buttons.

Key moulded components shall contain Freshield, which utilises a silver-based antimicrobial compound that reduces the growth of micro-organisms and mildew to protect the surfaces from discolouration, odours and degradation.

Cooling system uses R-134a or R-290a refrigerant.

Suitable for public building, gymnasiums, sports complexes, hospitals, schools, and offices.



MODEL CODE	M8WRSBFY 507449E	MWRSBF 507446
ACTIVATION	Bottle Filler: Contactless (Infrared sensor) Drinking Fountain: Manual (Push-button)	
SENSOR COVERAGE	Up to 5cm (approx.)	
FILTRATION	Green Filter (optional), Built-in 100 micron strainer	
AUTO-OFF WATER FLOW	Bottle Filler: Yes ; Drinking Fountain: No	
DRAINAGE TYPE	Built in drain, Removable drip tray	
EXTERIOR CHASSIS	Antimicrobial ABS Plastic, Brushed Stainless Steel	
DIMENSIONS	Heavy Duty Galvanised Steel	
ALCOVE HEIGHT	1143(H) x 502(W) x 483(D) (287 recessed)	
NET WEIGHT	73 kg	330 mm
POWER SUPPLY	220-240V, 50/60 Hz	NA
COOLING PERFORMANCE	60 LPH Rated Capacity & Base Rate (10°C in 21°C amb. temp.)	-
FULL LOAD AMPS	2.2 A	-
RATED WATTS	340 W	-
ENERGY SYSTEM	Refrigeration is on only when in use or if water temp increases during long period of standby.	-
COUNTRY OF ORIGIN	Mexico	
CERTIFICATIONS	ANSI/NSF 61, CABO/ANSI A117.1, ADA, CE (LVD, EMC, RoHS), WRAS	
WARRANTY	1 Year	

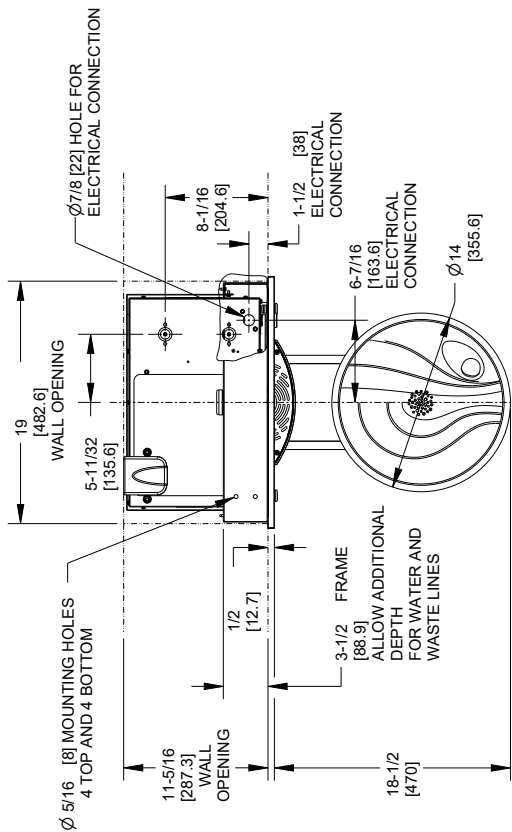

- NOTES:
- \*1. RECOMMENDED ADULT HEIGHT INSULATION SHOWN. ADJUST VERTICAL DIMENSIONS AS REQUIRED TO COMPLY WITH FEDERAL, STATE AND LOCAL CODES.
  - \*2. STOP VALVE, TRAP, PIPE CONNECTOR TO WASTE LINE NOT PROVIDED. SHORT RADIUS TRAP REQUIRED.
  - \*3. ALL DIMENSIONS ARE IN INCHES. DIMENSIONS IN BRACKETS [ ] ARE IN MILLIMETERS.

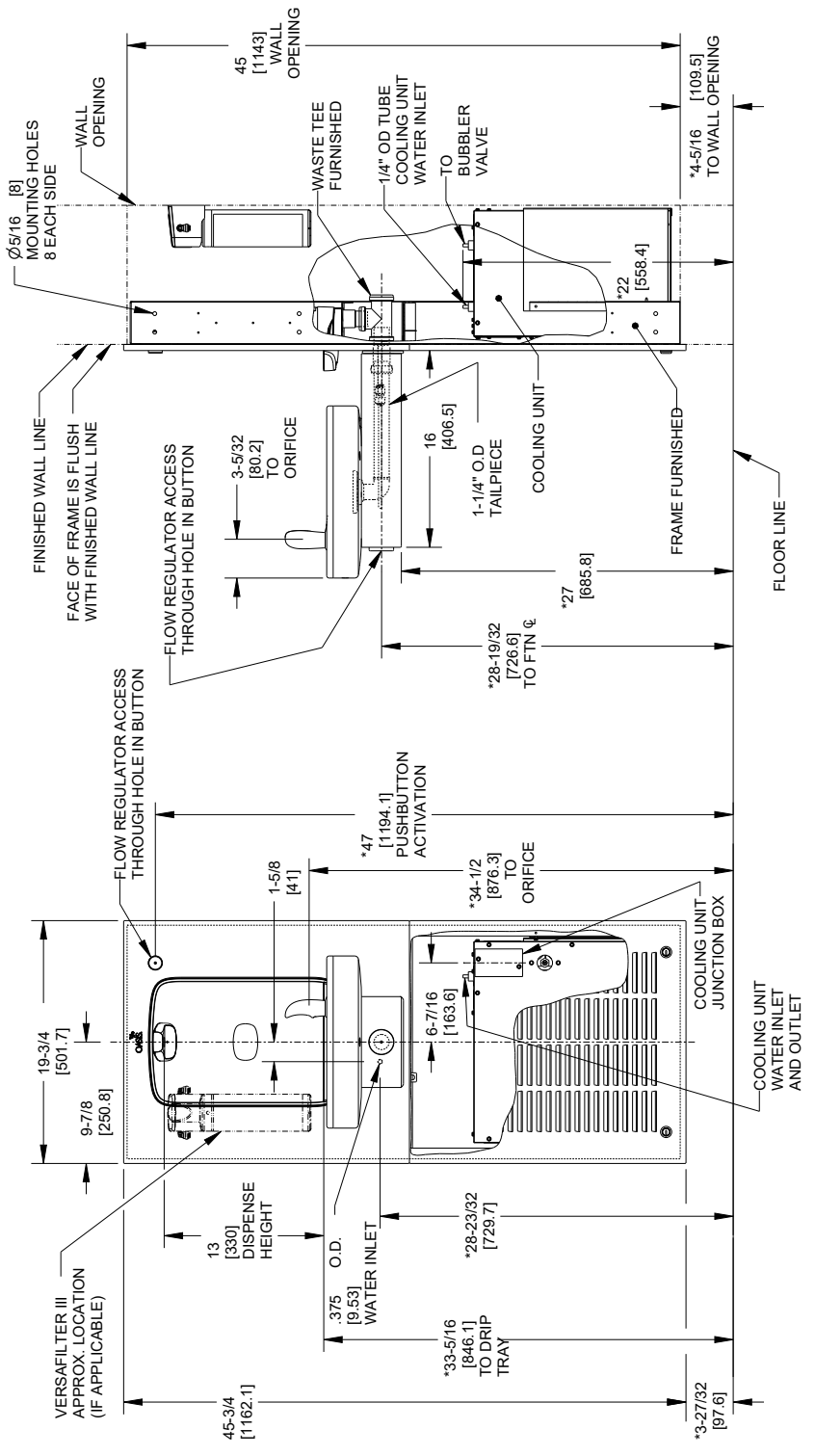

BOTTLE FILLER ONLY

www.oasiscoolers.eu  
info@oasis.ie

OASIS IRELAND  
Bunree Industrial Estate, Ballina,  
Co. Mayo, F26 D5R3, Ireland.  
+353 96 71222

OASIS POLAND  
ul. Gutenbergka 20,  
44-164, Gliwice, Poland  
+48 32 332 65 01